



# ATI-5010S

**Sump Brine Sensor**

---

## **INSTRUCTIONS**

**Installation and Maintenance of the  
ATI-5010S Interstitial Sump Brine Sensor**

### **IMPORTANT**

**Please read these installation and operating instructions completely and carefully before starting. Failure to do so will void warranty.**

filename:  
ATI.MAN.5007\_sump brine sensor

Revised, 10/17/2007  
Copyright © ATI, January 2006

---

**A.T.Monitors**, a division of Armstrong Technologies Inc.  
14 Birch Drive, Kemptville, Ontario, K0G 1J0, CANADA  
Tel: 613-258-5225 • Fax: 613-258-2698  
E-mail: [info@atmonitors.com](mailto:info@atmonitors.com) • Internet: [atmonitors.com](http://atmonitors.com)

# TABLE OF CONTENTS

Section Title	Page
<b>1 - WARRANTY</b> .....	<b>1</b>
1.1 - LIABILITY .....	1
1.2 - MODIFICATIONS AND SUBSTITUTIONS .....	1
1.3 - PRODUCT RETURN .....	1
<b>2 - PRODUCT INFORMATION</b> .....	<b>2</b>
2.1 - INTERSTITIAL SUMP BRINE SENSOR.....	2
<b>3 - PRODUCT DESCRIPTION</b> .....	<b>3</b>
3.1 - GENERAL DESCRIPTION.....	3
3.1.1 - SENSOR SPECIFICATIONS.....	3
3.2 - APPLICATIONS.....	3
<b>4 - INSTALLATION</b> .....	<b>5</b>
4.1 - LOCATION AND MOUNTING.....	5
4.1.1 - DOUBLE-WALL TANKS.....	5
4.2 - WIRING TO MONITORS.....	5
<b>5 - PREVENTIVE MAINTENANCE</b> .....	<b>6</b>
5.1 - SENSOR VERIFICATION.....	6
5.2 - TROUBLESHOOTING.....	6
5.2.1 - SUMP BRINE SENSOR DATA.....	6

## 1 - WARRANTY

The ATI-5010S Sump Brine Sensor is warranted against defects in material and workmanship for a period of one (1) year from date of shipment. During the warranty period, *Armstrong Technologies Inc. (ATI)* will repair or replace components that prove to be defective in the opinion of ATI. ATI is not liable for auxiliary interfaced equipment, or consequential damage. This warranty shall not apply to any product, which has been modified in any way, which has been repaired by any other party other than a qualified technician or authorized ATI representative, or when such failure is due to misuse or conditions of use.

### 1.1 - LIABILITY

All ATI products must be installed and maintained according to instructions. Only qualified technicians should install and maintain the equipment. ATI shall have no liability arising from auxiliary interfaced equipment, for consequential damage, or the installation and operation of this equipment. ATI shall have no liability for labour or freight costs, or any other costs or charges in excess of the amount of the invoice for the products.

THIS WARRANTY IS IN LIEU OF ALL OTHER WARRANTIES, EXPRESSED OR IMPLIED, AND SPECIFICALLY THE WARRANTIES OF MERCHANTABILITY AND FITNESS FOR A PARTICULAR PURPOSE. THERE ARE NO WARRANTIES THAT EXTEND BEYOND THE DESCRIPTION ON THE FACE THEREOF.

### 1.2 - MODIFICATIONS AND SUBSTITUTIONS

Due to an ongoing development program, ATI reserves the right to substitute components and change specifications at any time without incurring any obligations.

### 1.3 - PRODUCT RETURN

All products returned for warranty service will be by prepaid freight and they will only be accepted with an R.G.A. number issued by ATI. All products returned to the client will be freight collect.

## WARNING

<p><b>USING ELECTRICALLY OPERATED EQUIPMENT NEAR GASOLINE OR OTHER COMBUSTIBLE VAPOURS MAY RESULT IN FIRE OR EXPLOSION, CAUSING PERSONAL INJURY AND PROPERTY DAMAGE. CHECK TO ASSURE THE WORKING AREA IS FREE FROM SUCH HAZARDS DURING INSTALLATION OR WHEN PERFORMING MAINTENANCE, AND USE PROPER PRECAUTIONS.</b></p>
---

## 2 - PRODUCT INFORMATION

**NOTE:** This page must be filled-in at site by client, contractor or installer.

### 2.1 - INTERSTITIAL SUMP BRINE SENSOR

Sensor Part Number .....	_____
Sensor Serial Number .....	_____
Sensor Warranty Period .....	1 year
Operating Temperature .....	Water: 0 to +60°C (+32 to +140°F) Brine: -40 to +60°C (-40 to +140°F)
Operating Pressure .....	Ambient atmospheric pressure
<b>Electrical Rating</b> ( <i>maximum</i> ) .....	80 mA @ 120 VAC, 60 Hz, resistive 40 mA @ 240 VAC, 60 Hz, resistive 1 A @ 24 VDC, resistive

**Note:**

**All *Armstrong Technologies Inc.* products must be installed and maintained according to instructions, to ensure proper operation. Only qualified technicians should install and maintain the equipment.**

### 3 - PRODUCT DESCRIPTION

#### 3.1 - GENERAL DESCRIPTION

The ATI-5010S Interstitial Sump Brine Sensor is designed as a leak detection device for liquid filled tank sumps. The principle of operation of the sensor is simple. The unit has two (2) float elements contained in a housing which, when placed in a brine sump, will monitor the liquid level. Should the brine or any other liquid used in the interstitial space rise or fall, the sensor will send its indication to a remote monitor which will show there is a leak. The unique design allows for easy installation and immediate alarm response (see FIGURE 1).

The ATI-5010S Interstitial Sump Brine Sensor features:

- ◆ Reusable
- ◆ Instant response
- ◆ Intrinsically safe (when connected through an approved I.S. barrier, or to an ATI liquid monitor).

#### 3.1.1 - SENSOR SPECIFICATIONS

MONITORED LIQUIDS	Salt brine, glycol, water or other non-petroleum liquid
SENSOR	Dual magnetically activated float switch
INSTALLATION WIRING	Intrinsically safe, 4-conductor, type THWN or THHN cable
RESPONSE TIME	Instantaneous for any liquid
REPEATABILITY	Excellent even after repeated immersions without adjustment
OPERATING TEMPERATURE	Water: 0 to +60 °C (+32 to +140 °F) Brine: -40 to +60 °C (-40 to +140 °F)
STORAGE	10 YEARS @ -65 to +60 °C (-85 to +140 °F)

#### 3.2 - APPLICATIONS

See installation section for more details.

APPLICATION	TYPE	MONITORING LOCATION	MONITORED PRODUCT
Underground Storage Tanks	Steel/F.R.P. double-wall tanks	Near bottom of sump	Brine or other non-freezing product
Aboveground Storage Tanks			

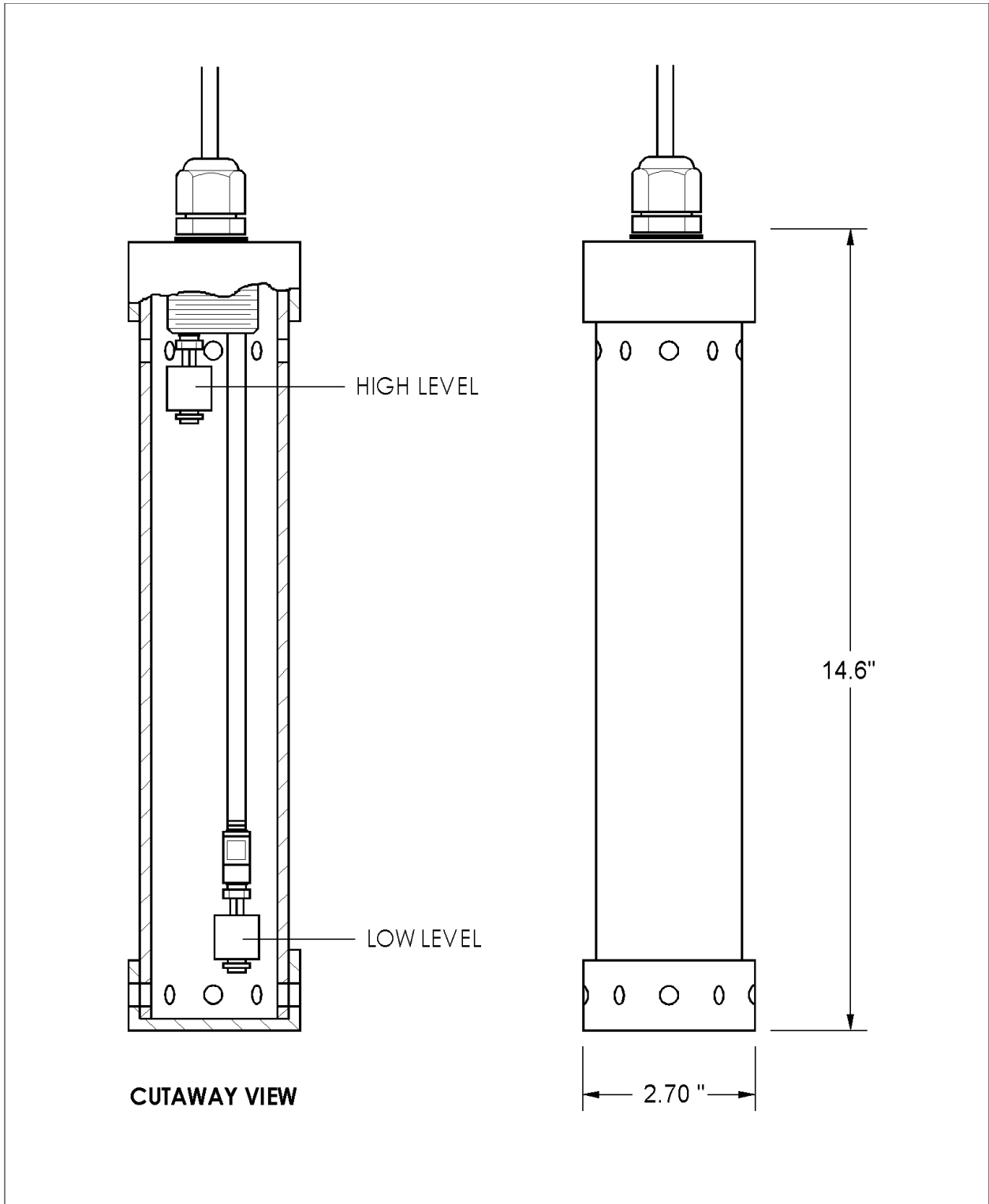

**FIGURE 1: Internal view and external dimensions of sump brine sensor.**

## 4 - INSTALLATION

### 4.1 - LOCATION AND MOUNTING

Although different practices can be followed, the proper method of installation and use of approved mounting hardware and sealing fittings is highly recommended to ensure sound and durable installation from sensors to monitor. **Refer to the attached drawing #2738-01 at the back of the manual.**

### WARNING

To comply with local municipal, provincial, or federal electrical regulations and for safety reasons, **ALL cables must pass through conduit seals installed between the hazardous and non-hazardous areas.**

#### 4.1.1 - DOUBLE-WALL TANKS

For the most reliable detection, the sensor should be immersed half way into the brine. This is due to the fact that the two sensing elements in the housing are located one at the top and one at the bottom.

### 4.2 - WIRING TO MONITORS

#### CAUTION:

**All cable entry must be through the bottom of the monitor enclosure only. Other entry locations will allow foreign materials to enter the enclosure, possibly causing damage to the internal components.**

Each sensor should be on a separate cable but more than one cable can be run through the same conduit. The cabling of the liquid sensors must be installed through conduit sealing fittings and conduit, separate and isolated from the vapour sensors.

On the liquid circuit, an unlimited number of ATI-5010S sump brine sensors can be connected in parallel to the terminals of one zone (channel). A water sensor (or Normally Open) sensor and a petroleum sensor **MUST NOT** be connected to the same terminals.

A typical wiring layout and jumper programming is shown at right. For more details on sensor wiring and programming, please refer to the instruction manuals for the monitors listed.

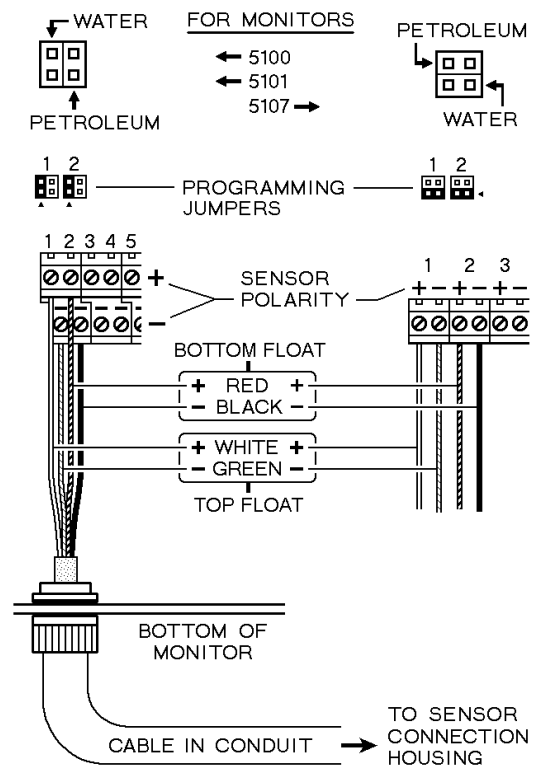

## 5 - PREVENTIVE MAINTENANCE

### 5.1 - SENSOR VERIFICATION

For verifying the sump brine level sensor, connect a digital multimeter (set for resistance) to each pair of wires (BLACK/RED and GREEN/WHITE). The resistance for each pair should read as an open circuit. Next, invert the sensor housing and observe the reading for each pair — it should drop to a very low resistance, typically less than 100 ohms.

**MAKE SURE TO VERIFY THE INTEGRITY OF EACH SENSOR DURING INSTALLATION.**

### 5.2 - TROUBLESHOOTING

If any unusual multimeter readings are obtained (other than those described in the Sensor Verification section), some wires may be shorted or the sensor may have been damaged during installation. **Remember to use caution when installing each ATI-5010S interstitial sump brine sensor.**

When verifying each sensor with a digital multimeter, make sure the readings obtained agree with the following sensor data.

#### 5.2.1 - SUMP BRINE SENSOR DATA

	Top Float	Bottom Float
Normal Status (no leak):	Circuit open (N/O)	Circuit open (N/O)
Alarm ON status (leak):	Circuit closed (N/C) Low resistance < 100 Ohms	Circuit closed (N/C) Low resistance < 100 Ohms