



ATI-DM335

Level Display Module

INSTRUCTIONS

**Installation, Operation & Maintenance
of the ATI-DM335 Level Display Module
for 12VDC Power Supply**

IMPORTANT

Please read these installation and operating instructions completely and carefully before starting. Failure to do so will void warranty.

filename:
ATI.MAN.335_level display module

Revised, 3/16/2009
Copyright © ATI, January 2006

A.T.Monitors, a division of Armstrong Technologies Inc.
14 Birch Drive, Kemptville, Ontario, K0G 1J0, CANADA
Tel: 613-258-5225 • Fax: 613-258-2698
E-mail: info@atmonitors.com • Internet: www.atmonitors.com

TABLE OF CONTENTS

Section Title	Page
1 - WARRANTY	1
1.1 - LIABILITY	1
1.2 - MODIFICATIONS AND SUBSTITUTIONS	1
1.3 - PRODUCT RETURN	1
2 - PRODUCT INFORMATION	2
2.1 - DISPLAY MODULE.....	2
2.2 - FACTORY SETTINGS.....	2
3 - PRODUCT DESCRIPTION	3
3.1 - GENERAL DESCRIPTION.....	3
4 - INSTALLATION	4
4.1 - LOCATION AND MOUNTING.....	4
4.2 - WIRING OF THE SYSTEM.....	5
4.2.1 - SHIELDING AND GROUND.....	5
5 - OPERATION AND CALIBRATION	6
5.1 - OPERATION.....	6
5.2 - CALIBRATION.....	6
6 - PREVENTIVE MAINTENANCE	7
6.1 - GENERAL.....	7
6.2 - VERIFICATION OF OPERATION.....	7

1 - WARRANTY

The ATI-DM335 Level Display Module is warranted against defects in material and workmanship for a period of one (1) year from date of shipment. During the warranty period, *Armstrong Technologies Inc. (ATI)* will repair or replace components that prove to be defective in the opinion of ATI. ATI is not liable for auxiliary interfaced equipment, or consequential damage. This warranty shall not apply to any product, which has been modified in any way, which has been repaired by any other party other than a qualified technician or authorized ATI representative, or when such failure is due to misuse or conditions of use.

1.1 - LIABILITY

All ATI products must be installed and maintained according to instructions. Only qualified technicians should install and maintain the equipment. ATI shall have no liability arising from auxiliary interfaced equipment, for consequential damage, or the installation and operation of this equipment. ATI shall have no liability for labour or freight costs, or any other costs or charges in excess of the amount of the invoice for the products.

THIS WARRANTY IS IN LIEU OF ALL OTHER WARRANTIES, EXPRESSED OR IMPLIED, AND SPECIFICALLY THE WARRANTIES OF MERCHANTABILITY AND FITNESS FOR A PARTICULAR PURPOSE. THERE ARE NO WARRANTIES THAT EXTEND BEYOND THE DESCRIPTION ON THE FACE THEREOF.

1.2 - MODIFICATIONS AND SUBSTITUTIONS

Due to an ongoing development program, ATI reserves the right to substitute components and change specifications at any time without incurring any obligations.

1.3 - PRODUCT RETURN

All products returned for warranty service will be by prepaid freight and they will only be accepted with an R.G.A. number issued by ATI. All products returned to the client will be freight collect.

WARNING

<p>USING ELECTRICALLY OPERATED EQUIPMENT NEAR GASOLINE OR OTHER COMBUSTIBLE VAPOURS MAY RESULT IN FIRE OR EXPLOSION, CAUSING PERSONAL INJURY AND PROPERTY DAMAGE. CHECK TO ASSURE THE WORKING AREA IS FREE FROM SUCH HAZARDS DURING INSTALLATION OR WHEN PERFORMING MAINTENANCE, AND USE PROPER PRECAUTIONS.</p>

2 - PRODUCT INFORMATION

NOTE: This page must be filled-in at site by client, contractor or installer.

2.1 - DISPLAY MODULE

Module Serial Number	_____
Power Supply Requirement	12 VDC
Power Supply Current (minimum)	200mA
Operating Temperature *	0 to +50 °C (+32 to +122 °F)
Relative Humidity	0 to 95 %, non-condensing
Display Type	3-1/2 digit LED display, 0.37" high
Alarm Indicators	LED's for Fail, Low alarm & High alarm
Input	4 to 20 mA DC
Output (optional)	4 to 20 mA DC into 250 Ohms
Relays (Fail, Low, High)	0.6A @ 110VDC/125VAC, 2A @ 30VDC

2.2 - FACTORY SETTINGS

DISPLAY:

4 mA	_____
20 mA	_____
Low Alarm Trip Point	_____
High Alarm Trip Point	_____

RELAYS:

Relay Coils

Low Alarm	<input type="checkbox"/> Normally Non-Energized	<input type="checkbox"/> Energized (optional)	_____
High Alarm	<input type="checkbox"/> Normally Non-Energized	<input type="checkbox"/> Energized (optional)	_____
Fail Alarm	Normally Energized		

Note:

All *Armstrong Technologies Inc.* products must be installed and maintained according to instructions, to ensure proper operation. Only qualified technicians should install and maintain the equipment.

3 - PRODUCT DESCRIPTION

3.1 - GENERAL DESCRIPTION

The ATI-DM335 Level Display Module is designed to accept a 4-20 mA signal from a variety of sensors or transmitters and offers local or remote liquid level readout, alarm indication and contacts. It features a 3,1/2 digit LED display for indicating liquid levels and has relay outputs for fail, low and high alarms. A 4-20 mA repeater output is available which matches the input signal. As a DIN rail mouted unit, this module can be combined with a wide assortment of monitoring instruments for local indication and alarm functions.

- 1) DISPLAY: 3-1/2 digit display for liquid level indication.
- 2) LED INDICATORS: LED indicators for power, fail, low and high alarm.
- 3) SENSOR/TRX CONNECTION: For sensor or transmitter connection to module.
- 4) POWER/MONITOR CONNECTION: For connection to power supply or host monitor.
NOTE: Use 250R resistor for 1-5V output only.
- 5) RELAY TERMINAL BLOCK: For connecting auxiliary equipment to the relay contacts.

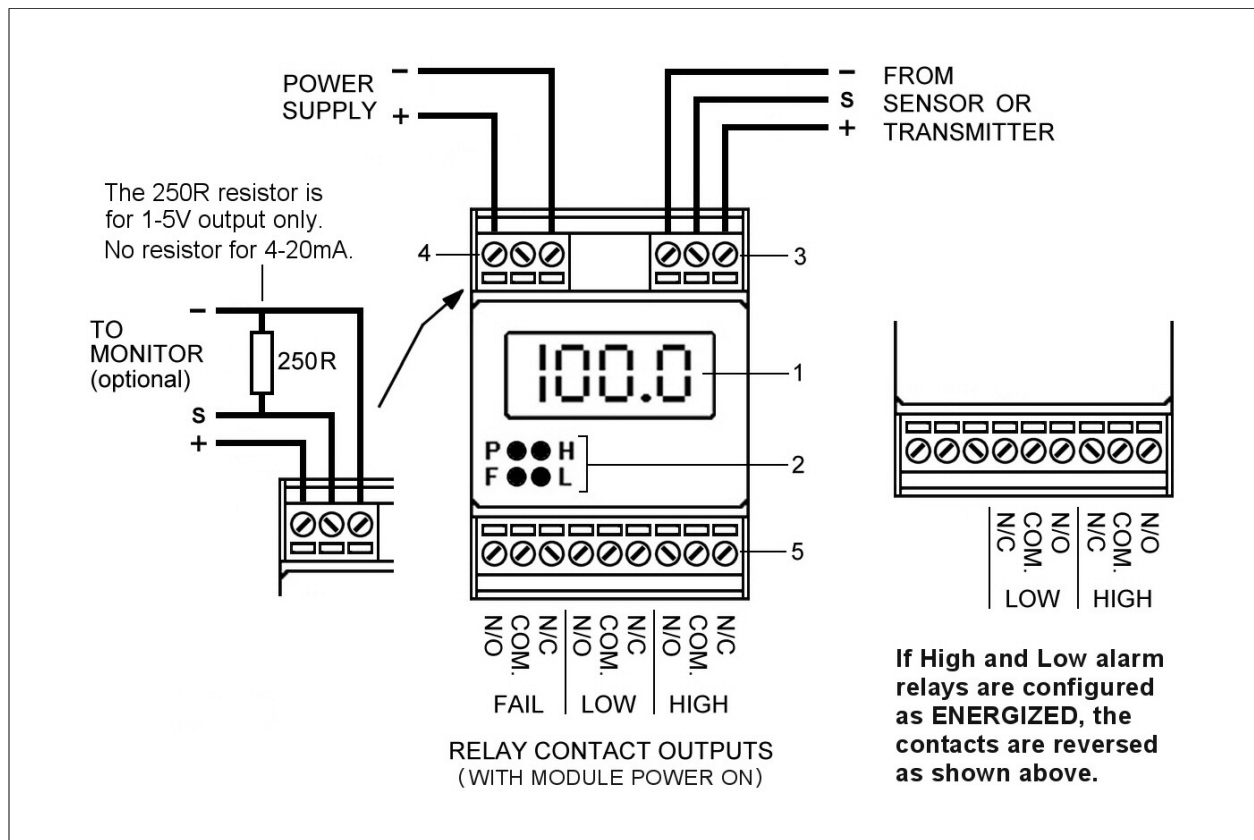

FIGURE 1: DM335 level display module wiring (front view).

4 - INSTALLATION

4.1 - LOCATION AND MOUNTING

Care should be taken to securely fasten the DM335 liquid level display module on a solid, non-vibrating surface or structure at eye level. Mount the monitor in an area where the unit can be observed periodically.

The module can be supplied in a NEMA-4X enclosure with transparent or windowed cover (as shown in FIGURE 2), in an explosion-proof housing, or can be simply snapped onto a DIN rail in an existing enclosure. To remove the module, a small flat screwdriver is required. Insert the tip of the screwdriver into the slot of the release tab, below the relay terminal blocks. Then, push the handle of the screwdriver towards the display and tilt the module in the same direction. This will pop the module off of the DIN rail.

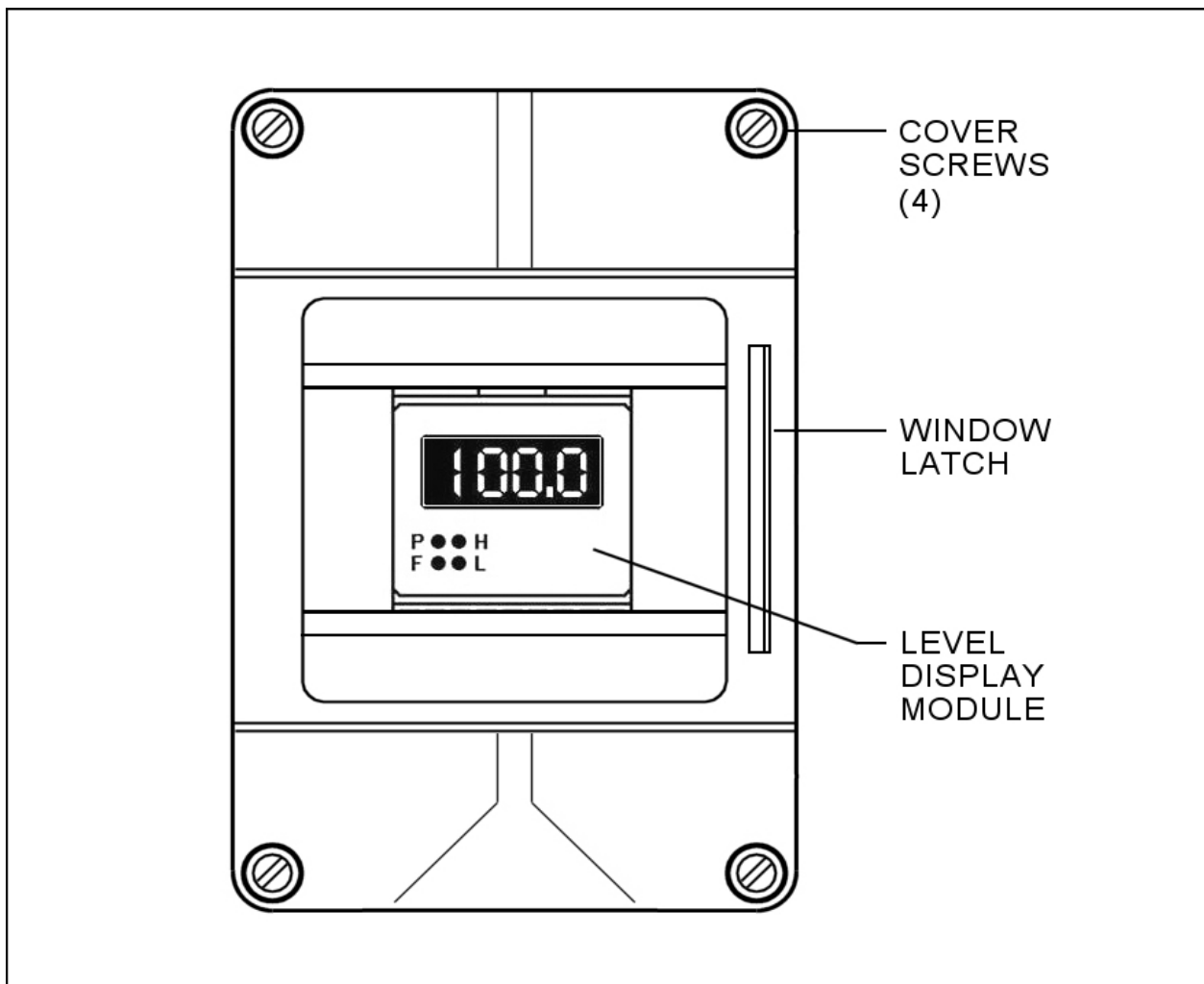

FIGURE 2: Example of mounting the housing with level display module.

4.2 - WIRING OF THE SYSTEM

Display Module: Connection to the host monitor/power supply is made at the MONITOR CONNECTION terminal block (See FIGURE 1). All connections should be made using shielded 2 or 3 conductor cable, depending if return signal wire is required. If an analog output is not required, short the "S" terminal to the "-" terminal.

Sensor: Each liquid sensor connects to the Sensor/Transmitter terminal block's "-", "S," "+" (see FIGURE 1). All connections should be made with shielded 2 or 3 conductor cable, depending on which sensor or transmitter is used.

CAUTION: The black "S" lead from the sensor must NEVER be connected to ground. This could cause erratic readings.

Relays: Three SPDT relays within the module are available, which change state with fail, low and high alarm causing contact transfer. Auxiliary control devices may be connected to these contacts providing they do not exceed relay ratings.

See section 2.2 FACTORY SETTINGS for relay set-up. Refer to FIGURE 1 for relay contact arrangement.

NOTE: For Class I locations, use appropriate conduit sealing fittings.

4.2.1 - SHIELDING AND GROUND



To obtain efficient shielding against EMI and RFI, the use of metal conduit from the sensor housing to the DM335 module enclosure is highly recommended.

Install a grounding bushing (as shown at left) on the conduit at the module enclosure and connect a lead from earth ground to the ground lug on the bushing. If shielded cable is also used, connect the braided shield of the cable to the same ground lug.

5 - OPERATION AND CALIBRATION

5.1 - OPERATION

When power is applied, the green power LED will light and the display will register a value representing the level of liquid.

If a fail condition occurs on the connected sensor the fail LED will activate and the fail relay will change state.

If the liquid level drops to the sensor's low alarm trip point setting the yellow LED will activate and the low alarm relay will change state.

If the liquid level rises to the sensor's high alarm trip point setting the red LED and high alarm relay will activate or de-activate depending on specified set-up.

The display on the module reflects the level of liquid seen by the connected sensor.

The signal current input from the sensor is repeated and fed to the module's output terminals). A monitoring device with a maximum impedance of 250 ohms may be connected to this output circuit. If an analog output is not required, short the "S" terminal to the "-" terminal.

5.2 - CALIBRATION

The DM335 level display module is factory calibrated based on customer requests and/or standards. Calibration should last for the life of the module. Recalibration is only necessary when changing the level trip points. See section 2.2 for FACTORY SETTINGS.

6 - PREVENTIVE MAINTENANCE

6.1 - GENERAL

The module enclosure should be brushed or wiped clean once a year or more, of any dust or dirt which settles on it, depending on the accumulation.

The unit SHOULD NOT be submerged in water or other liquids. Also, hosing and other conditions that could cause a liquid to enter the enclosure should be avoided.

6.2 - VERIFICATION OF OPERATION

To verify the operation of the system, make sure that each sensor and/or transmitter is still responding to liquid level changes and that the correct condition is shown on the display. This test should be performed every 2 months, but for more demanding applications, verification should be performed on a weekly basis.